

WHY AND HOW TO SHARPEN SQUEEGEES

Prepared by FIMOR NORTH AMERICA



CONTENTS :

- INTRODUCTION TO SHARPENING
- THE FUNCTION OF THE SQUEEGEE
- DUROMETER
- FREE-HEIGHT
- BLADE PROFILE
- BLADE EDGE
- WHY SHARPEN SQUEEGEE
- DOLLARS & SENSE OF SHARPENING
- HOW TO SHARPEN
- THE SALES PITCH
- APPENDIX

INTRODUCTION TO SQUEEGEE SHARPENING

There are plenty of benefits to properly maintaining production tools and equipment. A carpenter wouldn't last long with a dull saw blade. A machinist couldn't drill too many holes with a worn drill bit. They know that sooner or later, an end product made with poor tools will be unacceptable to the customer. They also know that dull and worn tools will slow production, often as much as 50%. Ultimately, they must consider their production costs. Is it more cost effective to refurbish such tools, or to replace them altogether?

The squeegee is one of the most important tools used in screen printing. Unfortunately, it is also one of the most neglected. It is important because it controls the ink deposit and affects the color and sharpness of the printed image. However, most screen printers produce tens of thousands of impressions without ever bothering to evaluate the squeegee because it "seems to work," no matter what shape it's in. Unless the blade has an obvious flaw (like a "nick" that leaves a streak in the image), production seems to go on forever. When streaks or other problems do occur, the blade simply gets replaced and production continues.

There are two things wrong with this picture of the squeegee:

1. Just because a squeegee prints with no major visual flaws, doesn't mean that the image has not changed between the first and last impression (print). This quality difference may be acceptable to the printer, but not to a customer looking for uniformity from print to print. Furthermore, some image flaws (often mistaken as symptoms of mechanical problems) may actually be related to the squeegee blade and not the printing equipment.
2. Replacing a squeegee blade is anywhere from 5 to 50 times more expensive (not to mention environmentally wasteful) than repairing (sharpening) it. Throwing away a squeegee after 50,000 impressions is like throwing away a drill bit after drilling only 50 holes - It's not very cost effective.

THE FUNCTION OF THE SQUEEGEE

Although it looks simple, the squeegee is a highly complicated part of the printing process. Unlike the ink-related press parts in other printing processes (doctor blades, ink rollers, pressure rollers, pads etc.), the squeegee alone must perform the following functions:

- forcing the ink into the screen mesh (**Figure 1A**, page 2)
- keeping the mesh in contact with the substrate (**Figure 2A**, page 2)
- adapting the mesh to the shape of the substrate (**Figure 2B**, page 2)
- removing the excess ink from the screen mesh (**Figure 1B**, page 2)

The squeegee must do each of these jobs well to make a good print. Yet, every time the squeegee's shape and size vary, it affects all four of these printing functions. **Figure 3** provides a diagram of the standard squeegee. While all the components are important, we need only consider four main features.

Durometer

This is a measure of the hardness/softness of the blade, which is usually made of polyurethane. The durometer, together with the physical size and shape of the blade determines its bending, flexing, and compression characteristics. Durometer has a numerical value of compression ranging from 55 to 90, as provided by a Shore A testing gauge. A blade with a value of 55-65 is considered soft, 66-75 is medium, and over 75 is called a hard durometer.

A hard-durometer blade fulfills three of the four printing functions better than a soft-durometer blade. Hard-durometer blades are also better at withstanding wear during printing. The only real advantage to a soft-durometer blade is that it can adapt the screen mesh to the substrate surface, a quality that is important when printing rough surfaces.

Free-height

This is the part of the blade that protrudes from the squeegee holder. It is an important dimension because it determines how much the blade will bend under pressure. This bending is proportional to the third power of the free height, for example, twice the dimension will result in $2^3=8$ times more bending (**Figure 4**).

When a squeegee blade bends, two things happen. First the angle between the blade and screen changes and, second, the amount of printing force transmitted to the substrate is reduced. You can think of the blade as a series of springs. When they are aligned with a force they transmit all the force. When the force is at an angle, the spring starts to bend and transmits less and less force (**Figure 5**). At a certain point, when the printing angle is reduced and insufficient printing pressure is applied, the squeegee can't work properly. It will adapt to the substrate poorly and it will remove less ink from the screen. The end result will be a thicker ink deposit. At this point most printers start to apply more pressure to the squeegee which will result in even more bending and totally unpredictable ink-deposit thickness.

Figure 1

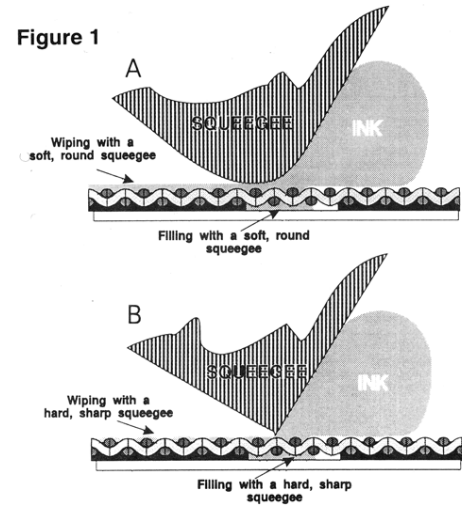

Figure 2

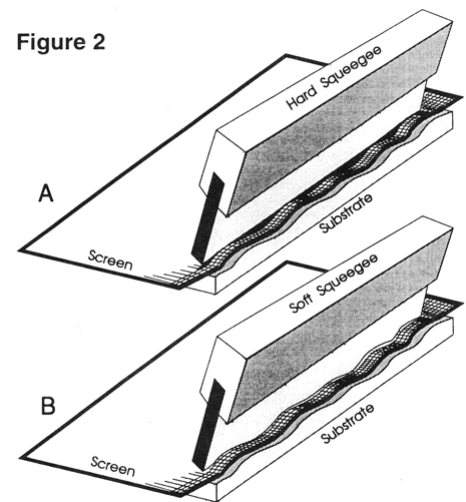
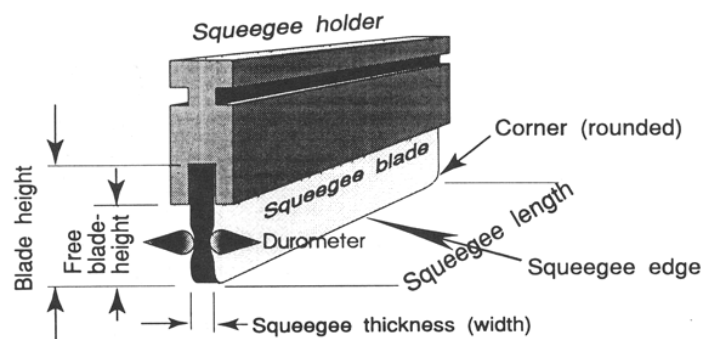

Figure 3



Blade profile

This is the shape of the squeegee blade as shown in **Figure 6**. Although the most frequently used shape is a simple rectangle, other shapes are also used for certain printing conditions. For example, a hard-durometer squeegee usually performs better than a soft one, but it has poor adaptability to the surface. By using a beveled blade, the printing edge becomes more flexible (similar to a soft durometer), while the rest of the squeegee retains its original stiffness.

The three basic profiles available to printers are the rectangle (or straight edge), various beveled shapes, and the round (bull-nose) shape. The rectangular shape provides medium adaptability, maximum printing pressure, and a printing angle that is close to the angle setting of the holder. The beveled shapes provide maximum adaptability, reduced printing pressure, and a printing angle that is less than the set angle. The round profile provides the least adaptability of all profiles, minimum printing pressure, and a printing angle that is independent of the angle setting on press (it is always at a minimum). For these reasons, it deposits the most ink. A chart explaining the selection of various profiles and durometers is shown in **Table I**, page 4.

Blade edge

This feature is the "working end" of the blade and it is the part that actually fulfills all four functions of the squeegee. The sharpness of this edge is the primary control of ink-deposit. A sharp edge will provide the minimum amount of ink and the maximum image definition. As the edge dulls and rounds, the ink deposit will increase. Eventually, this increase will adversely affect both color and image definition.

When printing large, simple designs with opaque inks, this change in color and image definition may not be visually apparent. However, when printing fine-lines, four-color process, or when using semi-opaque (UV) and transparent inks, you will quickly see the deterioration of the squeegee edge. Just compare the first and last prints of a long run where the squeegee was not sharpened during production.

Figure 4

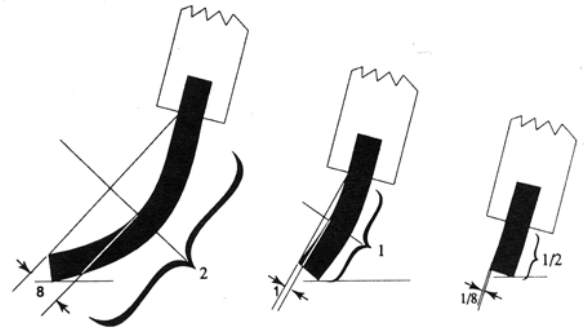

Figure 5

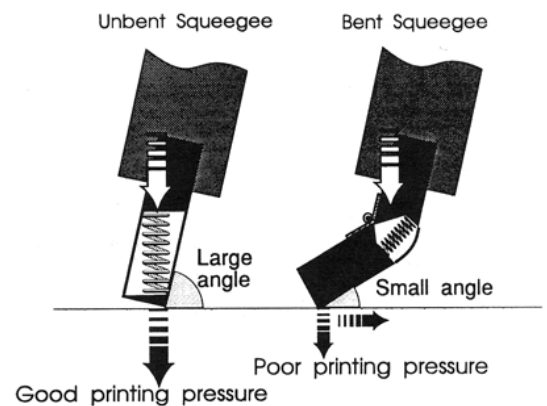

Figure 6

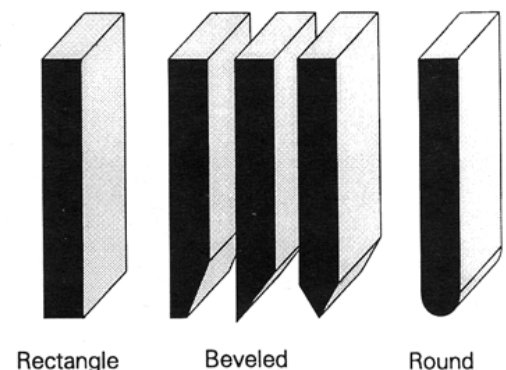













Table 1 - THE EFFECTS OF SQUEEGEE PROFILES / SHAPE

| | SQUEEGEE SHAPE | FORCE, MESH-OPENING, VISCOSITY | OFF-CONTACT SCREEN TENSION | ADAPTATION TO SUBSTRATE SURFACE | INK-LAYER THICKNESS, IMAGE DEFINITION |
|-------------------------|---|--|--|---|---|
| SOFT DUROMETER |  | Medium force, use with large mesh openings and low viscosity inks | Use with low tension screens or screens with minimum off-contact | Use on rough or uneven surfaces, dented press beds and poorly set up presses | Mediocre thickness control and image definition |
| |  | Medium force, use with large mesh openings and low viscosity inks | Use with low tension screens or screens with minimum off-contact | Use on rough or uneven surfaces, dented press beds and poorly set up presses | Poor thickness control and image definition ; use for coating applications |
| |  | Medium force, use with large mesh openings and low viscosity inks | Use with low tension screens or screens with minimum off-contact | Use on uneven contoured surfaces (containers, etc.) | Mediocre thickness control and image definition |
| |  | Medium force, use with large mesh openings and medium to low viscosity inks | Use with low tension screens or screens with minimum off-contact | Use on rough or uneven surfaces soft absorbent materials, worn presses | Poor thickness control and image definition ; use for coating applications |
| MEDIUM DUROMETER |  | High printing force, useful for a wide range of meshes and ink viscosities | Use with high or low tension screens with appropriate off-contact distance | Moderate adaptation : use on even surfaces with minimum texture | Good thickness control and image definition on well-set-up equipment |
| |  | High printing force, useful for a wide range of meshes and ink viscosities | Use with high or low tension screens with appropriate off-contact distance | Poor adaptation : use on even surfaces with minimum texture | Mediocre thickness control and image definition, use for coating |
| |  | Medium printing force, useful for a wide range of meshes and ink viscosities | Use with high or low tension screens with appropriate off-contact distance | Excellent adaptation : to a wide variety of uneven surfaces | Good thickness control and image definition on well-set-up equipment |
| |  | High printing force, useful for a wide range of meshes and ink viscosities | Use with high or low tension screens with appropriate off-contact distance | Poor adaptation : use on even surfaces with minimum texture | Mediocre thickness control & image definition, use for coating & low resolution |
| HARD DUROMETER |  | Highest printing force available; use on any mesh with high viscosity inks | Use on high tension screens with low off-contact | Very poor adaptation : use on smooth, even material on well-set-up presses | Excellent thickness control and definition on smooth even substrates |
| |  | Highest printing force available; use on any mesh with high viscosity inks | Use on high tension screens with low off-contact | Very poor adaptation : use only on smooth, even material on well-set-up presses | Good thickness control and definition on smooth even substrates |
| |  | Highest printing force available; use on any mesh with high viscosity inks | Use on high tension screens with low off-contact | Good adaptation : useful for most uneven surfaces | Excellent thickness control and definition on most surfaces |
| |  | Highest printing force available; use on any mesh with high viscosity inks | Use on high tension screens with low off-contact | Very poor adaptation : use only on smooth, even material on well-set-up presses | Good thickness control and definition on smooth even substrates |

WHY SHARPEN SQUEEGEES?

Now that you know what the squeegee is supposed to do, let's examine what prevents it from doing its job properly. When you insert a new piece of squeegee blade into a holder and clamp down with screws or clamping bars, you might assume the squeegee is press ready. Unfortunately, the answer is almost always « NO ». In more than 90% of all existing squeegee holders, the blade becomes distorted (**Figure 7**) because of uneven placement in the holder or because screw tension causes the blade to buckle. Few, if any, press operators can insert the blade and adjust the screws consistently.

This random pressure creates high and low spots along the blade that will distort the effective angle and pressure of the squeegee. The result is an unpredictable, uneven ink deposit and sometimes, dramatic color variations. To correct this problem, the squeegee must be « evened » out. ***It must be sharpened.***

Even a perfectly inserted blade will require "maintenance" once it has gone to press. Although you may not see it, the squeegee's edge begins to wear from the very first impression. This wear is gradual and, initially, it may actually improve the performance of the squeegee. (Minute imperfections on the edge become polished to a semi-gloss state which is ideal for uniform ink distribution.) Depending on material type and durometer of the blade, however, the wear on the edge will eventually create the following conditions:

1. *The edge will become rounded, leaving a progressively heavier ink deposit*
2. *The edge may become so highly polished it will tend to skip over the ink rather than spread it. This happens primarily with poster, water-based, or plastisol inks.*
3. *The edge may become swollen (because of solvent absorption) and small pieces of material will actually break off, leaving streaks in the image. This happens with highly aggressive inks (e.g., vinyl, polyester, and UV).*
4. *Excess wear along the edge will occur at some spots because of image design/ placement and press limitations.*

For example, **Figure 8**, shows a print with reverse lettering in a large printed area. If this job was done on a cylinder press, the blade might also wear at the grippers and create subsequent streaks.

Once the edge begins to deteriorate, it will only get worse. In some cases, you will notice streaks and light/dark areas in the image. In other cases, the color difference is not easy to see, but the reduced sharpness of the image and tiny skip marks resembling "fisheyes" tell you there is a problem. Unfortunately, printers often assume these flaws indicate a problem with the machine or the ink. The all too frequent solution is to adjust squeegee pressure, angle, and even change the ink, before someone finally examines the squeegee. In the mean time, the image gets worse and productivity suffers while operators try to cope with the problem.

Figure 7

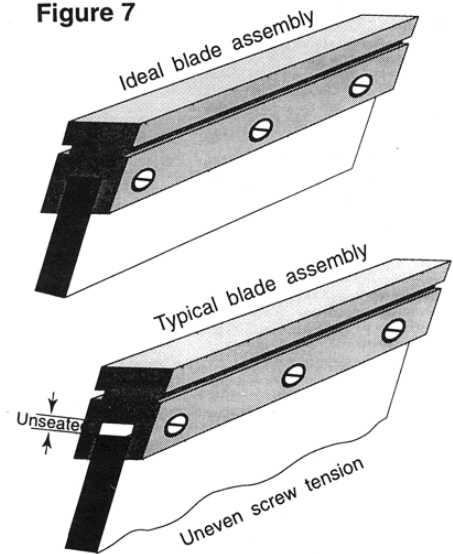
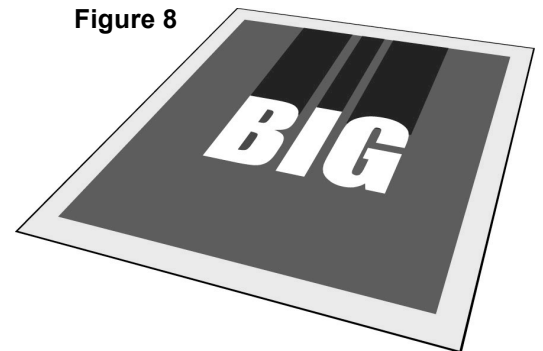

Figure 8



The simple solution to all these problems is to sharpen and maintain the squeegee throughout its useful life. Except for the initial sharpening of a new squeegee, maintaining a sharp edge depends on the blade quality and the number of impressions made before you notice a change in image quality.

There are no "rules" for how often a squeegee should be sharpened. In general, it is unlikely that a squeegee can perform at all past 50,000 impressions and, for quality printing, a squeegee should be evaluated every 5,000 impressions.

THE DOLLARS AND SENSE OF SHARPENING

Sharpening squeegees can benefit your business in three ways:

- 1. Sharpening improves print quality and increases customer satisfaction and sales.***
- 2. Sharpening reduces your production costs by eliminating wasted materials and down time due to poor squeegee performance and extra press setups.***
- 3. Sharpening reduces squeegee-blade and ink-consumption costs resulting in direct savings.***

Though it is difficult to calculate the actual dollar value of the first two benefits, they are as significant as any direct savings you can achieve. Therefore, when you try to justify the cost of a squeegee sharpener, you must remember that your actual savings may be 50%-100% higher than savings related directly to squeegee blade and ink consumption.

A Fimor sharpener will allow you to sharpen a new squeegee 25-50 times during its useful life. That's like getting 25-50 new squeegees for the price of one. Since the useful life of a squeegee is one year to a year and a half, you can plan to save on a 12 to 18 month supply of blades (after which you would have to replace them anyway). For example, if the average cost of new squeegee blade is \$50.40 (36" x \$1.40 per inch) your potential savings over replacing that one blade ranges from \$1 260 (12 mo.) to \$2520 (18 mo.). This would amount to a 50-66% savings on blade material alone.

How many times can you sharpen a squeegee? It depends on the free height of your new squeegee and remaining useable height after multiple sharpening. A typical new squeegee has a free height of 1.25", and we recommend a minimum height of no less than 0.75". This means you can sharpen away 0.50" material. If you remove only 0.01 0" per sharpening (ie, redressing the edge) your squeegee will last 50 sharpenings (0.50/0.01). If you sharpen less frequently but remove more material (ie, 0.020-0.030 for smoothing rough or damaged edges), your squeegee will last 25 or 16 sharpenings respectively.

Another direct cost savings from sharpening is a reduction in ink usage. A well-maintained, sharp squeegee edge will deposit 10%-20% less ink than a dull or rounded edge. Using 10%-20% less ink with an annual ink budget of \$50,000 would amount to savings of \$5,000-\$10,000.

How often should you sharpen a squeegee? It depends entirely on your quality requirements. If you want to maintain uniformity of ink deposit, color accuracy, and you want to reduce ink consumption, the squeegee should be sharpened every 5,000 impressions. On

the other hand, if you simply want to maintain a smooth, sharp edge, you may choose to sharpen every 20,000-30,000 impressions.

To determine the Return On Investment (ROI), consider the following:

Savings #1: The cost of squeegee blades will be reduced to 50%-66% of your current annual squeegee expense.

Savings #2: Ink costs will be reduced 10%-20%.

Savings #3: Production down-time/waste costs will be reduced 25%-50%.

Savings #4: Product quality and customer good-will will be improved.

For example, a company annually spends \$2,000 on squeegee blades, \$20,000 on ink and has a record of 50% down time. After sharpening for one year, this company could show a direct savings of at least \$3300 on squeegees and inks, and again as much on the indirect savings (#3 and #4 above).

Taking into consideration the cost of a sharpener manufactured by Fimor North America, an ROI can usually be achieved within one year or less.

HOW TO SHARPEN AND MAINTAIN SQUEEGEES

Hopefully, we've succeeded in convincing you that squeegee sharpening is both a profitable and a necessary step in screen printing. At this point, you need to know what actual sharpening entails. The first thing you need for sharpening is a piece of equipment that does everything we've discussed. Specifically, the ideal sharpener must be able to do the following things:

- 1. Provide a clean, smooth edge that does not leave streaks, marks or uneven color on the printed surface (substrate).**
- 2. Provide a uniform, straight edge that is parallel with the holder. (This will help press setup and eliminate the need for extra pressure to compensate for free-height variations.**
- 3. Sharpen all types of blades, regardless of sizes, composition or durometer.**
- 4. Accommodate squeegee holders (handles) in a variety of shapes and sizes.**
- 5. Provide accurate and adjustable material removal in small, measurable increments, allowing each squeegee to be sharpened repeatedly.**
- 6. Sharpen profiled squeegees when needed, as well as accommodate custom profiles for unique job requirements.**
- 7. Provide a variable (+/-) camber along the squeegee's entire length in order to make long squeegees conform to the screen.**

The second thing you need for squeegee care and maintenance is a clear procedure that spells out how and when to sharpen squeegees, and how to take care of them both on and off the press. These procedures should include (but not be limited to) the following guidelines:

- 1. Store a squeegee blade by laying it flat and not rolled into a "coil." Coiled squeegee will eventually become permanently curved.**

2. Rest assembled squeegees on the holders and not on the blades.
3. Clean blades immediately after printing, while the ink is easily removable. Scraping off dried ink can damage the blade.
4. Don't soak squeegees in solvents. Although squeegee materials are formulated to be solvent resistant (up to a point), they do absorb some solvents and will eventually become brittle.
5. Don't sharpen a squeegee right after cleaning because it is still soft and solvent-laden. We recommend a 12-24 hour "rest" for squeegees between use. Not only does this improve the sharpening process, it will also improve squeegee performance on press.
6. If a large amount of material has to be removed from the blade (e.g., due to a nick or a cut), first use a coarse grit for faster material removal and then switch to a fine grit for polishing.
7. Remove as little material as necessary. Once the edge is smooth and straight, there is no reason to continue sharpening. Only two or three sharpening cycles may be required to maintain a good edge.

THE SALES PITCH

As we have shown you, there are obvious cost and image-quality benefits to sharpening your blades. It's no surprise there are a variety of squeegee sharpeners available in today's market. However, most sharpeners cannot meet the specifications for an outstanding machine described on page 7, nor can they match the affordability of a Fimor sharpener.

More than 95% of the sharpeners used today are some kind of "grinding" device. Typically, these machines use a sanding wheel or belt. These wheels or belts usually come in a limited range of "grits" (coarse or fine) ranging from 60-120. While these options may satisfy average requirements, they cannot provide a smooth, polished edge on squeegee material. Also, if the wheel or belt is awkward or time-consuming to change, the operator will often "stick with" a worn or inappropriate grit and settle for lesser results.

Fimor uses only **industrial diamond-coated grinding wheels** because they offer extraordinary performance on any composition or durometer squeegee material. These wheels carry a 5-year warranty against delamination, however, if properly maintained, they should never need replacement. When attached to a Fimor Sharpener, these wheels provide a smooth, polished edge far superior to any sanding method. In addition, Fimor wheels come in a **variety of grit sizes ranging from 60-360**. Most Fimor sharpeners include one coarse and one fine grit wheel for the best possible results on all types of squeegees.

Unlike sanding methods, these wheels can be attached and removed quickly and easily. Furthermore, Fimor wheels are **available in various profiles for shaped squeegees**. (Seven profiles for smaller Fimor sharpeners and two for our large format models. (see **APPENDIX B.**) We will even design custom wheels for unique job requirements.

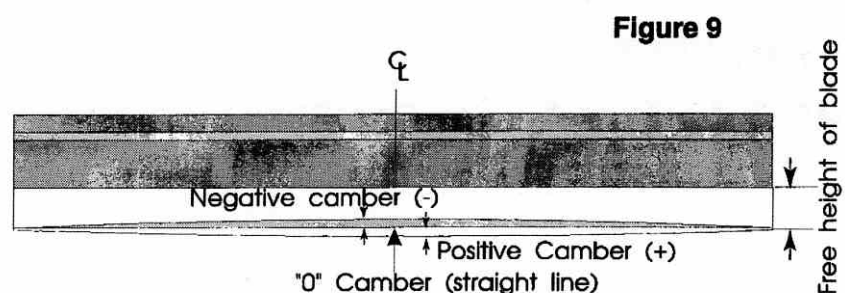

A recent addition to the sharpener market is a new system that slices the blade with a knife. Because cutting or slicing removes a substantial quantity of material during each sharpening, the 1/2" usable portion of the squeegee will typically last only about 5 sharpenings with such equipment. Because we believe that sharpening makes sense only if it saves money, all Fimor sharpeners feature micro-adjustment mechanisms to remove as little as .001" of material during sharpening.

Fimor sharpeners are designed to meet a variety of needs, providing small, inexpensive units for the manual print shop and large-format models for shops using squeegees up to 10 feet long. While many existing sharpeners (particularly belt sanders), require the operator to physically hold the squeegee during sharpening, ours **feature a clamping mechanism which holds the squeegee firmly by the blade** while the diamond wheel is moved (automatically or manually) across the squeegee. This feature is particularly useful for automated press users because the sharpener can accept any shape squeegee handle. Additionally, this configuration straightens the blade parallel to its handle. So, no matter how poorly a blade was fit into it's holder, the sharpener will bring it square.

Another unique advantage found on most Fimor sharpeners is the **variable camber (Figure 9)**. Models for squeegees 60" and longer (serilor® Kut and Kutronic series) are equipped with this feature. Why? Because many long squeegees tend to have a negative camber (curve) at the middle, either because of poor sharpening (e.g., a belt sander) or due to poorly assembled squeegees and/or presses. A negative camber on a squeegee will result in less pressure at the middle of the squeegee. This pressure difference will show up as a color variation, dot gain, and poorly defined edges in the center of the image. To correct this problem, serilor® Kut and Kutronic series sharpeners have a positive camber set at 0.030-0.060" (depending on the length). This camber can be reset to any value (including a straight "0") by the user.

Whether your needs are **large or small, automated or manual**, Fimor has the squeegee sharpener for your requirements. Take a look at the brief descriptions for all our machines in **APPENDIX A** and then compare them with any other squeegee sharpener on the market.

At Fimor, we understand the role that squeegees and squeegee sharpening play in producing a quality screen-printed product. We hope this booklet has helped to clarify the importance of this seemingly simple tool. For additional information, specifications, distributor names, and current pricing on all our equipment, contact any of Fimor offices world-wide.

APPENDIX A: OUR SQUEEGEE SHARPENERS

serilor® Eez Kit: (available in North America only)

A money-saving build-it-yourself kit designed for very small or start-up operations using only manual-printing handles. The user supplies the table top and base materials and simply attaches the components included in the kit. It sharpens squeegees up to 36" long. Two diamond wheels (60 and 120 grit) are included.

Serilor® Short-Cut:

The first precision small-format, manual squeegee sharpener to sharpen blades 20" (51cm) and under. The portable table-top design fits anywhere and used an indestructible diamond-sharpening wheel. A 120 grit wheel is supplied with this unit.

serilor® Maxi:

Designed to accommodate a range of squeegee handle configurations, the Maxi is ideal for garment, graphic, container, or electronics printers using automatic presses. The sturdy design holds up to a 38" (97 cm) squeegee by the blade while the operator moves the wheel in fixed tracks across the squeegee. Two diamond wheels (60 and 120 grit) are included.

serilor® Maxitronic:

This fully-automated version of the serilor®Maxi will accommodate squeegees up to 37" (94cm) and controls all variables for optimum accuracy. The operator simply presets the number of cycles and the diamond wheel will automatically advance to remove .002"-.004" (2.-4 mils) of material per cycle. Unit includes a stand and vacuum system and two diamond wheels (60 and 120 grit).

48" serilor® Maxitronic:

Recommended for larger textile and graphics printers, this slightly longer version of the Maxitronic includes all the features of the original, but sharpens squeegees up to 48" (122cm) long. This unit is built on a stand and includes a vacuum system and two diamond wheels (60 and 120 grit).

serilor® Kut:

The Kut offers precision sharpening with two models for squeegees up to 60" or 76" (153 or 193cm) long. The unit's sturdy design holds the squeegee by the blade and even compensates for potential bending or bowing of long blades. Two diamond wheels (100 and 360 grit) are included.

serilor® Kutronic:

A fully-automated sharpener with four models for squeegees up to 60"(153cm), 76"(193cm) 96" (244cm) or 120" (305cm) long. Offers the same quality features of the **Kut** and controls all variables for optimum accuracy. Two diamond wheels (100 and 360 grit) are included.

APPENDIX B: OUR SHAPED WHEELS

All sharpeners include two (2) straight edge diamond wheels: Small machines include 60 and 120 grit while Kut and Kutronics include 100 and 360 grit. All wheels shown are offered as optional accessories.

Square-Edge Wheel (small and large wheels available):

Diameter: small wheel 1"; large wheel 6"

Grits available: small wheels: 60; 120; 230; 360,
large wheels: 100; 360

Primary use: sharpening and polishing straight-edge (square) squeegee blades.

Center-Sharp Wheel (small wheel only):

Major Diameter: 1.480"

Included Angle: 60°

Grits available: 220 and 360

Primary Use: Beveling 3/16" squeegee blades to improve adaptation to rough or uneven substrates.

Center-Bevel Wheel (small wheel only):

Major diameter: 1.540"

Included angle: 90° or 70°

Grits Available: 220

Primary Use: Beveling Standard 3/8" squeegee blades to improve adaptation to rough or uneven substrates.

Round Wheel (small wheel only):

Major Diameter: 1.500"

Radius of Curvature: 0.220"

Grits available: 120

Primary use: Rounding standard 3/8" squeegee blades for heavier ink deposit.

Round/Sharp Combo Wheel (small wheel only):

Major Diameter: 1.500"

Radius of Curvature: 0.125"

Grits Available: 120

Primary use: For applications requiring variable ink-deposit thickness (e.g., garment printing). One edge of the squeegee remains square, the opposite edge has a 1/8" radius curve for heavier ink deposit.

Hollow-Grind Wheel (small and large wheels):

Small wheel Major Diameter : 1.500"

Large wheel Major Diameter: 6.000"

Included angle: 160°

Grits Available: 230

Primary Use: Hollow profiling for sharp, flexible outer edges to improve image definition and eliminate streaks in both fine-line printing and coating applications.

Chisel Wheel (small wheel only)

Major Diameter: 1.750"

Included Angle: 30°

Grits available: 230

Primary Use: Chisel profiling for improved adaptation in container decorating or when printing rough or uneven surfaces.

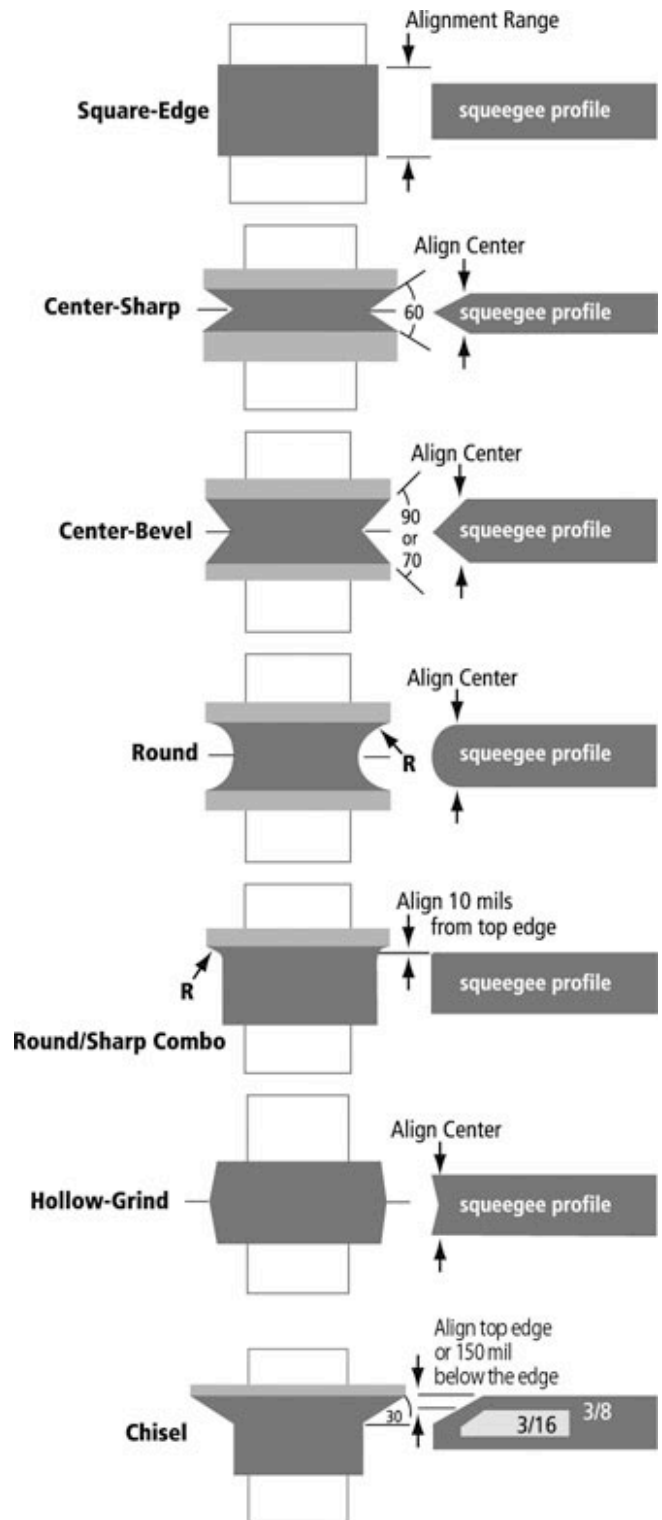

Notes :

Copyright©2005 by FIMOR NORTH AMERICA, a FIMOR company, SARASOTA, Florida, USA.
All rights reserved. Contents of this manual may not be reproduced or stored in any form without permission
from Fimor North America